

The **RZM centric clamping vice** is ideal for 5-axis processing centres. Without any additional substructures or special jaws, the centric clamping unit holds the workpiece securely – with a minimum interference contour.

SKB claw jaws included in scope of delivery.

Technical features:

- Steel basic body hardened and ground
- High position of the clamping jaws
- The spindle situated at the top, close to the jaws
- long jaw ways
- Outstanding guidance characteristics are based on a patentprotected jaw guidance system

Customer advantage:

- Very open design for optimised chip removal, so even in heavy machining operations it is easy to keep the vice clean
- Highly suitable for the use with SKB claw jaws. Unfinished parts and parts for processing with a strength up to max. 900N/mm² are securely clamped with a clamping depth of 2,5 mm
- Flat jaws compatible to NC-Compact vice RKE

Tool group A32
Type 725-00 RZM

Item no.	178910	178911
Jaw width A	125	125
Design	long design	short design
B min.	23	23
B max.	222	142
B1	17-216	17-136
C	128	128
D	298	218
E	196,5	196,5
F	260	180
N	156,5	156,5
U	20	20
X	6	6
Clamping force kN	25	25
Tightening torque Nm	150	150
Weight kg	20,3	17,4

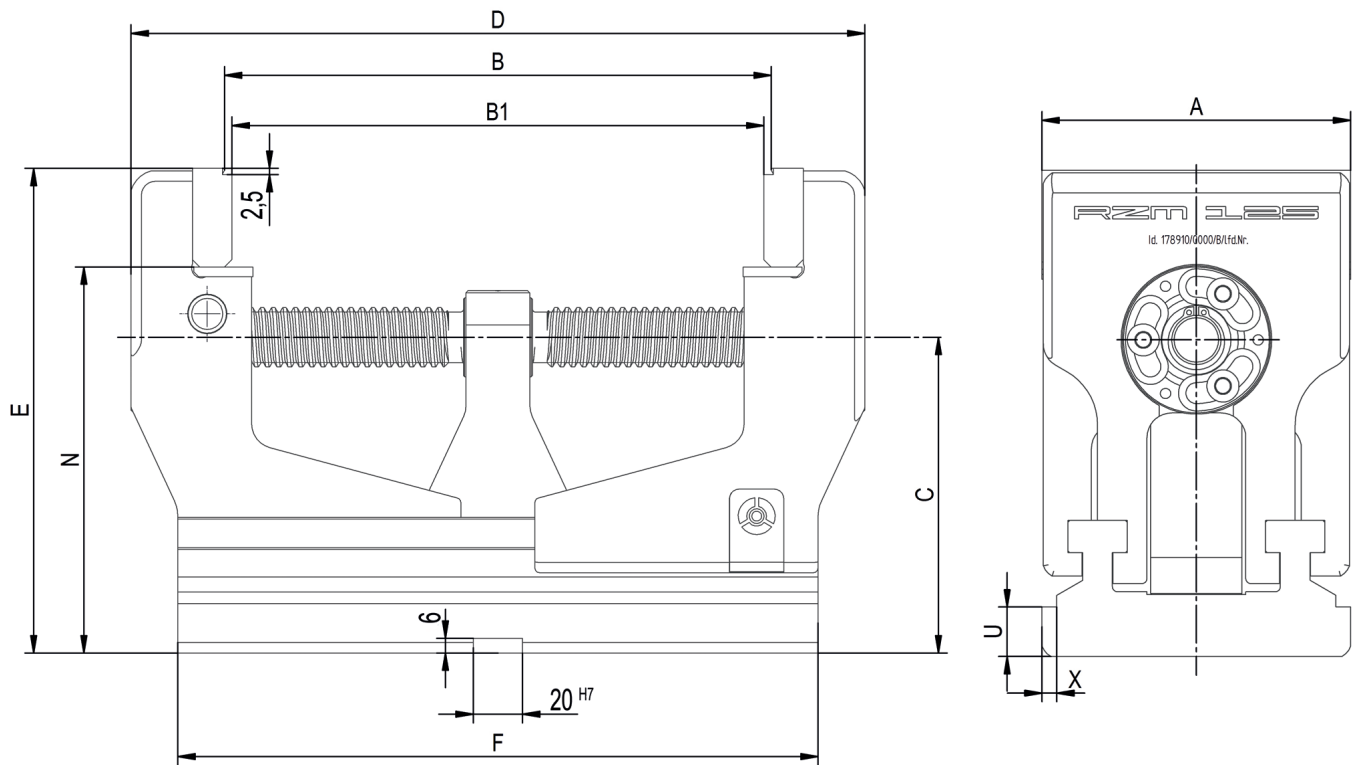

Accessories RZM

A37 Typ 746-54 Claw jaws without step universal for clamping depth >2,5mm	Item no.	Contents of delivery	Size	Width	Height	Thickness
	166667 ■	set	125	125	40	16



A37 Typ 746-54 Claw jaws with fine step 2,5 mm clamping depth	Item no.	Contents of delivery	Size	Width	Height	Thickness
	166520 ■	set	125	125	40	16



A37 Type 721 Normal jaw SGN one side smooth, one side grooved, both sides ground	Item no.	Contents of delivery	Size	Width	Height
	158897 ●	set	125	125	39,7



A37 Type 721 Normal jaw fine checked SGNf reversible, used to increase the specific surface pressure (higher retention force), one side fine checked, one side longitudinally checked	Item no.	Contents of delivery	Size	Width	Height
	163225 ●	set	125	125	39,7

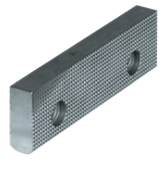

A37 Type 726-52 V-jaw PB horizontal and vertical	Item no.	Contents of delivery	Size	Width	Height	Thickness	Height prism	Clamping range horizontal	Clamping range vertical
	158641 ■	set	125	125	40	20	24	15-40	18-60

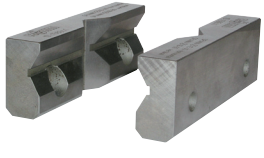

Accessories RZM

A37 Type 721-52 Normal jaw SGNA with movable workpiece locator, hardened and ground; only suitable for twin-clamping	Item no.	Contents of delivery	Size	Width	Height
	150740 ■	piece	125	135	39,6

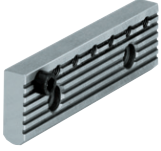

A37 Type 721 Draw-down jaws SNF with spring plate, hardened and ground	Item no.	Contents of delivery	Size	Width	Height
	077105 ●	set	125	135	39,6



A37 Type 728-00 V-jaw and standard jaw SBO soft and gunmetal-finished, with work support	Item no.	Contents of delivery	Size	Width	Height	Clamping range	
						Horizontal	Vertical
317260 ●	set	125	135	39,8	3-13	6-40	

