

HSK-C

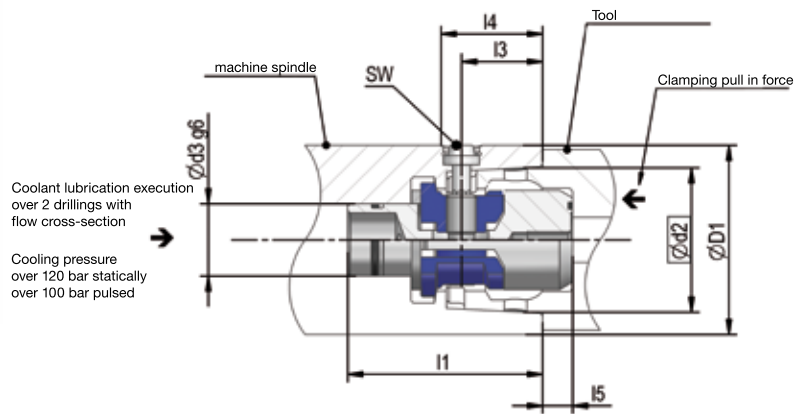

Tool group C 15
Type 288-60

Built-in Clamping System HSK-C
for hollow taper shanks
DIN 69893 HSK-A and -C
Inner spindle taper contour with
intergrated driving notches

Item no.	760530	784603	812617	831435	586214	475170	475172	483213	831306
Initial size D ₁	25	32	40	50	63	80	100	125	160
Taper Ø d ₂	19	24	30	38	48	60	75	95	120
d ₃ ^{H7/g6}	10	12	15	18	24	32	40	48	60
l ₁	28	34	45	55	65	80	97,5	124	160
l ₃	11,4	14	17,5	21,5	27	34	42	53	68
l ₄	15	18,5	22	27	34	42	53	67	85
l ₅	6	8	8	10	10	12,5	12,5	16	16
Key SW	2,5	2,5	3	4	5	6	8	10	12
Tightening torque Nm	1,8	2,5	3	8	14	25	42	80	100
Pull-in-force kN	3,5	5	6,8	11	18	30	45	70	115
Flow cross section mm ²	-	6,3	10,6	14,1	27,7	56,5	100,5	100,5	157
Adjusting screw complete Item no.	760628	1176471	760463	760464	760465	760466	760467	812815	831311

HSK-D

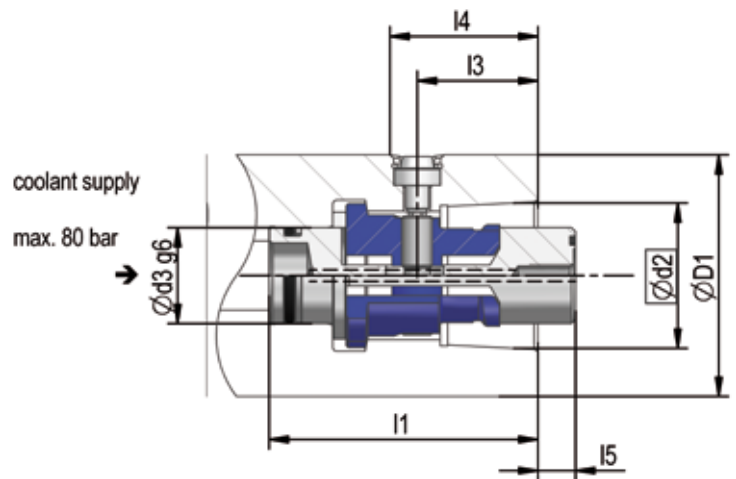

Tool group C 15
Type 288-61
Built-in Clamping System HSK-D with central coolant supply,
for hollow taper shanks
DIN 69893 HSK-B, D, E, F
without driving slots at the hollow tapered shank end

Item no.	466327	1011116	845214	1011117	1011118	1011119	1011098
Initial size D_1	40	50	63	80	100	125	160
Taper $\varnothing d_2$	24	30	38	48	60	75	95
$d_3^{H7/g6}$	16,5	20	25	32	36	50	60
l_1	45	57,5	70	90	104	134	162
l_3	20	25	31,5	40	48	61	76,2
l_4	30	32	40	48	56	72	90
l_5	8	8	10	10	12,5	12,5	16
Key SW	2,5	3	4	5	6	8	10
Tightening torque Nm	2,5	3	8	14	25	42	80
Pull-in-force kN	5	6,8	11	18	30	45	70
Adjusting screw complete Item no.	870032	760464	870034	870035	870036	870037	870029

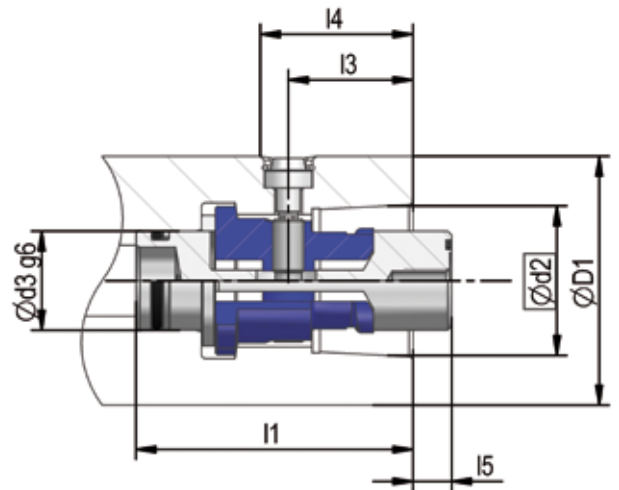

Tool group C 15
Type 288-61
Built-in Clamping System HSK-D without central coolant supply,
for hollow taper shanks
DIN 69893 HSK-B, D, E, F
without driving slots at the hollow tapered shank end

Item no.	784624	784932	881798	895272	895304	466323	870583
Initial size D_1	32	40	50	63	80	100	125
Taper $\varnothing d_2$	19	24	30	38	48	60	75
$d_3^{H7/g6}$	13	16,5	20	25	32	36	50
l_1	36	45	57,5	70	90	104	134
l_3	16	20	25	31,5	40	48	61
l_4	20	25	32	40	48	56	72
l_5	6	8	8	10	10	12,5	12,5
Key SW	2,5	2,5	3	4	5	6	8
Tightening torque Nm	1,8	2,5	3	8	14	25	42
Pull-in-force kN	3,5	5	6,8	11	18	30	45
Adjusting screw complete Item no.	870031	870032	760464	870034	870035	870036	870037